

# Operating Instructions

## COMPACT DISC PLAYER

# PD-6700

# PD-5700

# PD-4700

COMPACT  
disc  
DIGITAL AUDIO

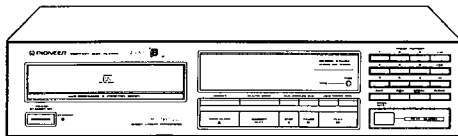

PD-4700

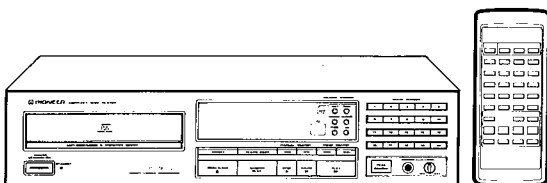

PD-6700

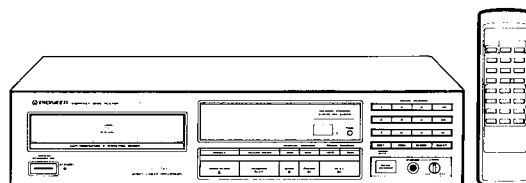

PD-5700

Thank you for buying this Pioneer product. Please read through these operating instructions so you will know how to operate your model properly. After you have finished reading the instructions, put them away in a safe place for future reference. In some countries or regions, the shape of the power plug and power outlet may sometimes differ from that shown in the explanatory drawings. However, the method of connecting and operating the unit is the same.

**WARNING:** TO PREVENT FIRE OR SHOCK HAZARD, DO NOT EXPOSE THIS APPLIANCE TO RAIN OR MOISTURE.

### IMPORTANT NOTICE

[For U.S. and Canadian models]

The serial number for this equipment is located on the rear panel. Please write this serial number on your enclosed warranty card and keep it in a secure area. This is for your security.

[For Canadian model] (Only PD-6700)

**CAUTION:** TO PREVENT ELECTRIC SHOCK DO NOT USE THIS (POLARIZED) PLUG WITH AN EXTENSION CORD, RECEPTACLE OR OTHER OUTLET UNLESS THE BLADES CAN BE FULLY INSERTED TO PREVENT BLADE EXPOSURE.

**ATTENTION:** POUR PREVENIR LES CHOCS ELECTRIQUES NE PAS UTILISER CETTE FICHE POLARISEE AVEC UN PROLONGATEUR UNE PRISE DE COURANT OU UNE AUTRE SORTIE DE COURANT, SAUF SI LES LAMES PEUVENT ETRE INSEREES A FOND SANS EN LAISSER AUCUNE PARTIE A DECOUVERT.

"This product complies with the Radio Interference requirements of the EC (European Community) Directive 87/308/EEC."

THE POWER SWITCH IS SECONDARY CONNECTED AND THEREFORE DOES NOT SEPARATE THE UNIT FROM MAINS POWER IN STANDBY POSITION.

### LINE VOLTAGE SELECTOR SWITCH

Only multi-voltage models are provided with this switch. U.S., Canadian, European, U.K., and Australian models are not provided with this switch. Mains voltages in Saudi Arabia are 127V and 220V only. Never use this model with 110V setting in Saudi Arabia.

The line voltage selector switch is located on the rear panel of this player. Before your player is shipped from the factory, the switch is set to the power requirements of the player's destination. Check that it is set properly before plugging the power cord into the outlet. If the voltage is not properly set or if you move to an area where the voltage requirements differ, adjust the selector switch as follows:

- Use a medium-sized (flat-blade) screwdriver. Insert the tip of the screwdriver into the groove of the selector switch and turn it so that the power voltage marking of your area points to the arrow.

VOLTAGE SELECTOR

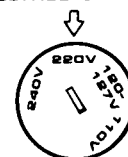

**PIONEER**  
The Art of Entertainment

## IMPORTANT 1



The lightning flash with arrowhead, within an equilateral triangle, is intended to alert the user to the presence of uninsulated "dangerous voltage" within the product's enclosure that may be of sufficient magnitude to constitute a risk of electric shock to persons.



**CAUTION:**  
**TO PREVENT THE RISK OF ELECTRIC SHOCK, DO NOT REMOVE COVER (OR BACK). NO USER-SERVICEABLE PARTS INSIDE. REFER SERVICING TO QUALIFIED SERVICE PERSONNEL.**



The exclamation point within an equilateral triangle is intended to alert the user to the presence of important operating and maintenance (servicing) instructions in the literature accompanying the appliance.

## IMPORTANT 2

If the apparatus is fitted with AC mains power outlet(s), see **REAR PANEL FACILITIES** for convenient connection of additional Hi-Fi component(s). Make all connections to the AC outlet(s) and the signal terminals first. Connect the plug to the wall socket last, make sure that the power switch is off.

### FOR USE IN THE UNITED KINGDOM

The wires in this mains lead are coloured in accordance with the following code:

Blue: Neutral  
Brown: Live

As the colours of the wires in the mains lead of this apparatus may not correspond with the coloured marking identifying the terminals in your plug proceed as follows:

The wire which is coloured blue must be connected to the terminal which is marked with the letter N or coloured black.

The wire which is coloured brown must be connected to the terminal which is marked with the letter L or coloured red.  
Do not connect either wire to the earth terminal of a three pin plug.

Equipment sold in the U.K. is not supplied with a power plug.

# SAFETY INSTRUCTIONS

**READ INSTRUCTIONS** — All the safety and operating instructions should be read before the appliance is operated.

**RETAIN INSTRUCTIONS** — The operating instructions should be retained for future reference.

**HEED WARNING** — All warnings on the appliance and in the operating instructions should be adhered to.

**FOLLOW INSTRUCTIONS** — All operating and use instructions should be followed.

**WATER AND MOISTURE** — The appliance should not be used near water — for example, near a bathtub, washbowl, kitchen sink, laundry tub, in a wet basement, or near a swimming pool, etc.

**LOCATION** — The appliance should be installed in a stable location.

**WALL OR CEILING MOUNTING** — The appliance should not be mounted to a wall or ceiling.

**VENTILATION** — The appliance should be situated so that its location or position does not interfere with its proper ventilation. For example, the appliance should not be situated on a bed, sofa, rug, or similar surface that may block the ventilation openings; or, placed in a built-in installation, such as a bookcase or cabinet that may impede the flow of air through the ventilation openings.

**HEAT** — The appliance should be situated away from heat sources such as radiators, heat registers, stoves, or other appliances (including amplifiers) that produce heat.

**POWER SOURCES** — The appliance should be connected to a power supply only of the type described in the operating instructions or as marked on the appliance.

**POWER-CORD PROTECTION** — Power-supply cords should be routed so that they are not likely to be walked on or pinched by items placed upon or against them. Pay particular attention to cords at plugs, convenience receptacles, and the point where they exit from the appliance.

**POLARIZATION** — If your purchased product is provided with a polarized power plug, please read the following instructions. This product is equipped with a polarized alternating current line plug (a plug having one blade wider than the other). This plug will fit into the power outlet only one way. This is a safety feature. If you are unable to insert the plug fully into the outlet, try reversing the plug. If the plug should still fail to fit, contact your electrician to replace your obsolete outlet. Do not defeat the safety purpose of the polarized plug.

**CLEANING** — The appliance should be cleaned only with a polishing cloth or a soft dry cloth. Never clean with furniture wax, benzene, insecticides or other volatile liquids since they may corrode the cabinet.

**POWERLINES** — An outdoor antenna should be located away from power lines.

**NONUSE PERIODS** — The power cord of the appliance should be unplugged from the outlet when left unused for a long period of time.

**OBJECT AND LIQUID ENTRY** — Care should be taken so that objects do not fall and liquids are not spilled into the enclosure through openings.

**DAMAGE REQUIRING SERVICE** — The appliance should be serviced by a Pioneer authorized service center or qualified service personnel when:

- The power-supply cord or the plug has been damaged.
- Objects have fallen, or liquid has been spilled into the appliance.
- The appliance has been exposed to rain.
- The appliance does not appear to operate normally or exhibits a marked change in performance.
- The appliance has been dropped or the enclosure damaged.

**SERVICING** — The user should not attempt to service the appliance beyond that described in the operating instructions. For all other servicing, contact the nearest Pioneer authorized service center.

**OUTDOOR ANTENNA GROUNDING** — If an outside antenna is connected to the antenna terminal, be sure the antenna system is grounded so as to provide some protection against voltage surges and built up static charges.

In the U.S.A. section 810 of the National Electrical Code, ANSI/NFPA No. 70-1984, provides information with respect to proper grounding of the mast and supporting structure, grounding of the lead-in wire to an antenna discharge unit, size of grounding conductors, location of antenna discharge unit, connection to grounding electrodes, and requirements for the grounding electrode. See Fig. A.

**CART** — An appliance and cart combination should be moved with care. Quick stops, excessive force, and uneven surfaces may cause the appliance and cart combination to overturn.



NEC — NATIONAL ELECTRIC CODE

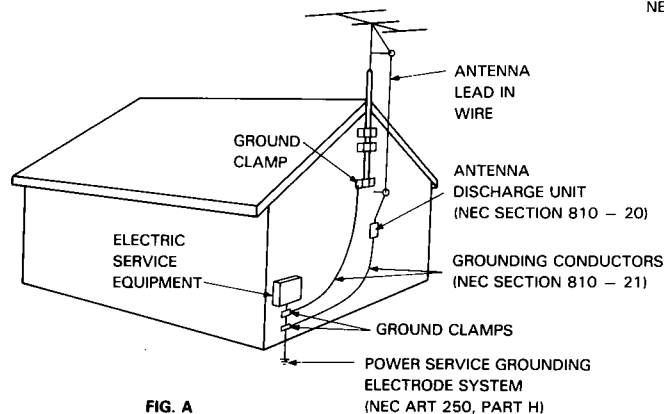

**[FOR EUROPEAN AND U.K. MODELS]**

**CAUTION**

This product contains a laser diode of higher class than 1. To ensure continued safety, do not remove any covers or attempt to gain access to the inside of the product.  
Refer all servicing to qualified personnel.

The following caution label appear on your player.

Location: rear of the player



**[FOR U.S. MODEL]**

**CAUTION**

- Use of controls or adjustments or performance of procedures other than those specified herein may result in hazardous radiation exposure.
- The use of optical instruments with this product will increase eye hazard.

**INFORMATION TO USER [FOR U.S. MODEL]**

This equipment generates and uses radio frequency energy and if not installed and used properly, that is, in strict accordance with the manufacturer's instructions, may cause interference to radio and television reception. It has been type tested and found to comply with the limits for a Class B computing device in accordance with the specifications in Subpart J of Part 15 of FCC Rules, which are designed to provide reasonable protection against such interference in a residential installation. However, there is no guarantee that interference will not occur in a particular installation.

If this equipment does cause interference to radio or television reception, which can be determined by turning the equipment off and on, the user is encouraged to try to correct the interference by one or more of the following measures:

- reorient the receiving antenna
- relocate this equipment with respect to the receiver
- move this equipment away from the receiver
- plug this equipment into a different outlet so that equipment and receiver are on different branch circuits.

If necessary, the user should consult the dealer or an experienced radio/television technician for additional suggestions. The user may find the following booklet prepared by the Federal Communications Commission helpful:

"How to Identify and Resolve Radio-TV Interference Problems".

This booklet is available from the US Government Printing Office, Washington, D.C., 20402, Stock No. 004-000-00345-4.

*The above instructions apply only to units which will be operated in the United States.*

**[For Canadian model]**

This digital apparatus does not exceed the Class B limits for radio noise emissions from digital apparatus set out in the Radio Interference Regulations of the Canadian Department of Communications.

**POWER-CORD CAUTION**

Handle the power cord by the plug. Do not pull out the plug by tugging the cord and never touch the power cord when your hands are wet as this could cause a short circuit or electric shock. Do not place the unit, a piece of furniture, etc., on the power cord, or pinch the cord. Never make a knot in the cord or tie it with other cords. The power cords should be routed such that they are not likely to be stepped on. A damaged power cord can cause fire or give you an electrical shock. Check the power cord once in a while. When you find it damaged, ask your nearest PIONEER authorized service center or your dealer for a replacement.

## CONTENTS

|   |    |
|---|----|
| <b>ABOUT THESE OPERATING INSTRUCTIONS</b> .....   | 4  |
| <b>CAUTIONS REGARDING HANDLING</b> .....  | 5  |
| <b>CONNECTIONS</b> .....  | 6  |
| <b>CONFIRM SUPPLIED ACCESSORIES</b> .....   | 7  |
| <b>PUT BATTERIES INTO REMOTE CONTROL UNIT</b> .....   | 7  |
| <b>REMOTE CONTROL OPERATIONS</b> .....  | 7  |
| <b>PANEL FACILITIES</b> .....   | 8  |
| <b>BASIC OPERATION</b> .....  | 9  |
| To play a compact disc .....  | 9  |
| To remove a disc .....  | 9  |
| Using the time button .....   | 10 |
| <b>VARIOUS OPERATIONS</b> .....   | 10 |
| To begin playback from a particular track .....   | 10 |
| During playback of one track, to advance immediately to the next track (track search) ..... | 11 |
| To start fast forward or fast reverse during playback (manual search) .....                 | 11 |
| To display the playing time of a particular track ...                                       | 11 |
| HI-LITE scan .....  | 11 |
| To repeat playback (repeat play) .....  | 11 |
| To choose random selection of the playback order (random play) .....                        | 11 |
| To search for the peak volume level within a disc (peak search) .....                       | 11 |
| Adjusting the sound volume .....  | 11 |
| <b>TO SELECT PLAYBACK OF TRACKS IN A SPECIFIC ORDER</b> .....                               | 12 |
| Inputting the playback program .....  | 12 |
| About the direct program function .....   | 12 |
| About the pause program function .....  | 12 |
| To stop programmed playback .....   | 13 |
| To erase the program memory .....   | 13 |
| To erase a program .....  | 13 |
| To confirm contents of the programmed memory .....  | 13 |
| To change the contents of programmed tracks already input .....                             | 13 |
| <b>TO PLAYBACK A CD TO MATCH THE LENGTH OF A CASSETTE TAPE</b> .....                        | 14 |
| To perform compu program edit by designating the length of tape to be used .....            | 14 |
| <b>TROUBLESHOOTING</b> .....  | 15 |
| <b>SPECIFICATIONS</b> .....   | 16 |

## ABOUT THESE OPERATING INSTRUCTIONS

The contents found in these Operating Instructions are based on the PD-6700 model, but they are also applicable to the PD-5700 and PD-4700 models.

### Differences between Models

|                        | PD-6700                    | PD-5700                    | PD-4700                    |
|------------------------|----------------------------|----------------------------|----------------------------|
| Remote control unit    | YES                        | YES                        | NO                         |
| Control cord           | YES<br>(U.S. and Canadian) | YES<br>(U.S. and Canadian) | YES                        |
| Headphones jack        | YES                        | YES                        | YES<br>(U.K. and European) |
| Optical digital output | YES                        | NO                         | NO                         |

### Power cord connections and functions:

- The functions of this component may not all operate correctly, depending on where the unit's power cord is connected. Please note the following chart:

| Where connected<br>Function | •Wall outlet<br>•Auxiliary outlet (UNSWITCHED)<br>on stereo amplifier | •Audio timer<br>•Auxiliary outlet (SWITCHED)<br>on stereo amplifier |
|-----------------------------|---|---|
| Timer play                  | Will not operate.   | Will operate.   |
| Programmed play             | Program is memorized.   | Program is erased.  |
| Sound volume                | Volume level is memorized.  | Volume level is erased.   |

## CAUTIONS REGARDING HANDLING

### Location

**Install the player in a well ventilated location where it will not be exposed to high temperature or humidity.**

Do not install the player in a location which is exposed to direct rays of the sun, or near to hot appliances or radiators. Excessive heat can adversely affect the cabinet and internal components. Installation of the player in a damp or dusty environment may result in malfunction or accident. (Also avoid installation near cookers etc., where the player may be exposed to smoke from oil, steam or heat.)



### Precautions regarding installation

- Placing and using the compact disc player for long periods on heat-generating sources such as amplifiers will affect performance. Avoid placing the player on heat-generating sources.
- Install this compact disc player as far as possible from tuners and TV sets. A compact disc player installed in close proximity to such equipment may cause noise or degradation of the picture. Such noise may be particularly noticeable when an indoor antenna is used. In such a case, make use of an outdoor antenna, or turn off power to the compact disc player.
- Please place this unit on a level surface.

### Condensation

When the player is brought into a warm room from previously cold conditions or when the room temperature is suddenly increased, condensation may form inside and the player may not be able to attain its full performance. In cases like this, allow the unit to stand for about an hour or raise the room temperature gradually.



### Cleaning discs

- The presence of fingerprints or smudges on the surface of the disc will not directly affect the recorded signals; but depending on the degree of contamination, the brightness of the light reflected from the signal surfaces may be reduced, causing degradation of sound quality. Always keep your discs clean by wiping them gently with a soft cloth from the inner edge toward the outer perimeter.

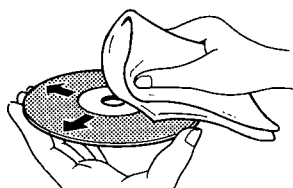

- If a disc becomes very dirty, wet a soft cloth in water. After wringing it out well, wipe the dirt away gently, and then remove any water drops with another soft dry cloth.
- Do not use record cleaning sprays or anti-static agents on discs. Also, never clean discs with benzene, thinner, or other volatile solvents which may cause damage to the disc surface.

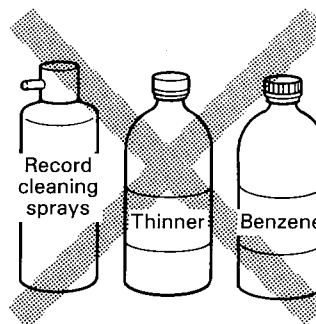

### Storing discs

- Discs are made of the same kinds of plastic used for conventional analog audio records. Be careful not to allow discs to warp; always store discs in their cases vertically, avoiding locations with high heat or humidity, or extremely low temperatures. Avoid leaving discs in cars and on the seats being exposed to direct sunlight since this can be harmful.
- Always read and abide by the precautionary notes listed on the disc labels.

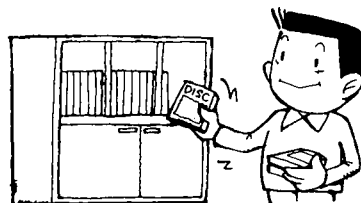

### Cleaning the player

To clean the front panel and unit housing, wipe with a soft, dry cloth. For stubborn dirt, wet a soft cloth with a mild detergent solution, wring well, then wipe off the dirt. Also use a dry cloth to wipe the surface dry. Do not use volatile liquids such as benzene or thinner which are harmful to the unit.

### CD lens cleaner

The player's pickup lens should not become dirty in normal use, but if for some reason it should malfunction due to soiling, ask your nearest PIONEER authorized service center. Lens cleaners for CD players are commercially available, but special care should be exercised in their use since some may cause damage to the lens.

## CONNECTIONS

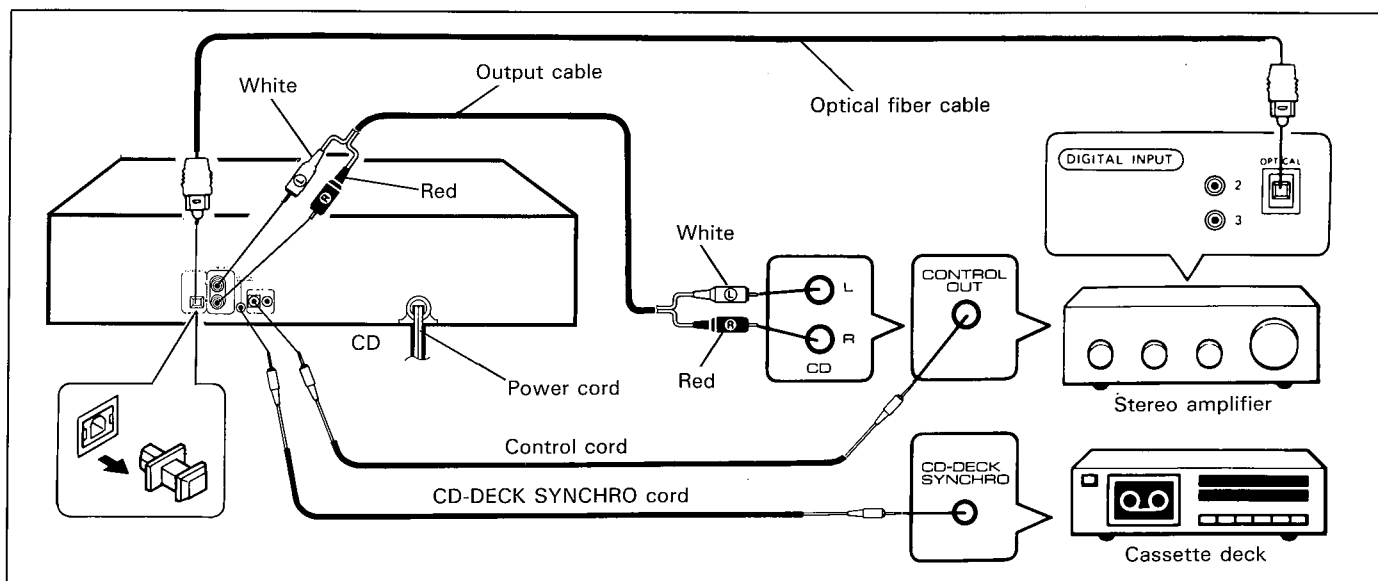

### CONNECTING THE OUTPUT CABLE:

Connect the plugs on one end of the cable to your amplifier's input terminals (CD or AUX), and those on the other end to the output terminals on this CD player.

- When connecting the cord, insert the white plugs into the left (L) channel, and the red plugs into the right (R) channel.
- Be sure to connect all plugs fully into their terminals.
- Never connect the CD player to your amplifier's turntable (PHONO) terminals, since sound will be distorted and proper playback will not be possible.

### CONNECTING THE POWER CORD:

Insert the power cord's plug into an accessory AC outlet on your amplifier, or into a normal household outlet.

### CONNECTING THE OPTICAL FIBER CABLE:

Applicable model: PD-6700

Connect the plug of the optical fiber cable to a stereo amplifier or D/A converter equipped with a digital input connector. Do not connect to the normal "CD INPUT" or other audio connectors of your amplifier. Also, do not connect this plug if not using the digital output function.

#### NOTE:

- No sound will be produced if the digital output is connected to an amplifier having different optical signal standards.
- The sound volume control cannot be done through the digital output terminal.

### Handling precautions for the optical fiber cable (sold separately)

- Do not bend the cable at sharp angles. Doing so may damage the cable. When installing in a rack, take special care. When storing the cable for storage, coil with 5-15/16 in (15 cm) diameter or larger.
- When connecting, insert the plug fully. Avoid an incomplete connection.
- Use an optical fiber cable 10 feet (3 m) or less.
- Avoid the optical fiber cable plug being scratched or exposed to dust. If there is dust, wipe off with a soft cloth.
- When an optical fiber cable is not connected, place the dust cap on the optical terminal (OPTICAL).

### REMOTE CONTROL AMPLIFIER OPERATION:

Applicable models: PD-4700 (All models)  
PD-5700 (U.S. and Canadian models),  
PD-6700 (U.S. and Canadian models).

If your amplifier features the  mark, connect the accessory control cord between the Amplifier's CONTROL OUT terminal and the CD player's CONTROL IN terminal.

- You can then use the remote control unit furnished with your amplifier to perform PLAY, PAUSE, STOP and TRACK operations on the CD player.
- For details regarding connection and operation, consult the Operating Instructions accompanying your stereo amplifier.
- These terminals do not need to be connected if you do not intend to use this function.

#### NOTE:

- When the control cord is connected to the CONTROL IN terminal, the remote control unit cannot be used to control the player directly. The remote control unit must be pointed at the amplifier's remote sensor.
- Be sure to connect both of the control cord's plugs securely to the CONTROL IN and CONTROL OUT terminals. Do not connect only one end of the cable.

### About the CD-DECK SYNCHRO recording function:

- This function facilitates edit recording from CD to cassette tape when the CD player is connected to a Pioneer cassette deck equipped with a CD-DECK SYNCHRO terminal. For details, consult the Operating Instructions accompanying the cassette deck featuring the CD-DECK SYNCHRO mark.

#### NOTE:

The CD-DECK SYNCHRO recording function will not operate if the digital output connector is connected alone. In order to enable this function, the normal output cable must also be connected to the stereo amplifier.

## CONFIRM SUPPLIED ACCESSORIES

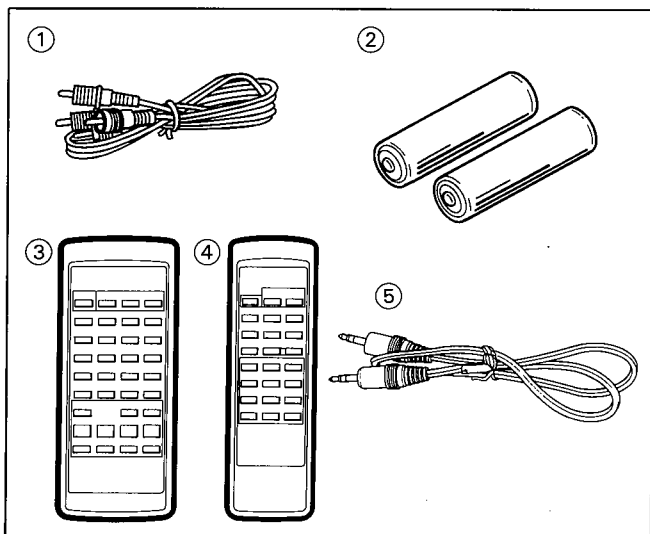

- ① Output cable
- ② "AAA" (RO3) batteries  
(Applicable models: PD-5700, PD-6700)
- ③ Remote control unit  
(Applicable model: PD-6700)
- ④ Remote control unit  
(Applicable model: PD-5700)
  - The remote control unit and batteries are located behind the foam packing.
- ⑤ Control cord  
(Applicable models: PD-4700 [all];  
PD-5700  
[U.S. and Canadian models only];  
PD-6700  
[U.S. and Canadian models only]).

## PUT BATTERIES INTO REMOTE CONTROL UNIT

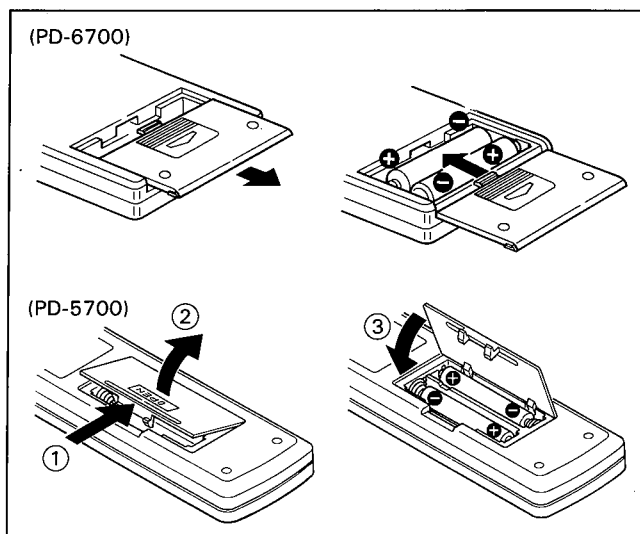

Open the lid of the battery compartment on the rear of the remote control unit, and insert the batteries, taking care to align the (+) and (-) polarities correctly.

### NOTE:

- In order to prevent battery leakage, remove the batteries when not using the remote control unit for an extended period (one month or more). In the event of battery leakage, carefully wipe away any battery fluid inside the compartment, and replace the batteries with new ones.
- Do not allow books or other objects to rest on top of the remote control unit, since the buttons may be depressed, causing faster exhaustion of the batteries.

Improper use of batteries can cause dangerous leakage or rupture. Be sure to observe the following safety points:

- Insert batteries with positive (+) and negative (-) polarities aligned correctly as shown inside the battery compartment.
- Do not mix new and used batteries.
- Even batteries of the same type may have differing voltages depending on the manufacturer. Do not mix different types of batteries.

## REMOTE CONTROL OPERATIONS (PD-6700, PD-5700 ONLY)

When operating the remote control unit, point the unit's infrared signal transmitter at the remote control receiver (REMOTE SENSOR) on the front panel of the player. The remote control unit can be used within a range of about 7 meters (23 feet) from the remote sensor, and within angles of up to about 30 degrees.

### NOTE:

- If the remote control sensor window is in a position where it receives strong light such as sunlight or fluorescent light, control may not be possible.
- Operate the PD-4700 using the remote control unit which accompanies the amplifier. (See Page 6)

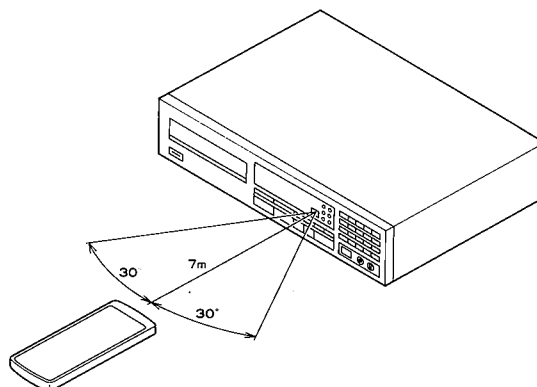

# PANEL FACILITIES

**PD-6700**

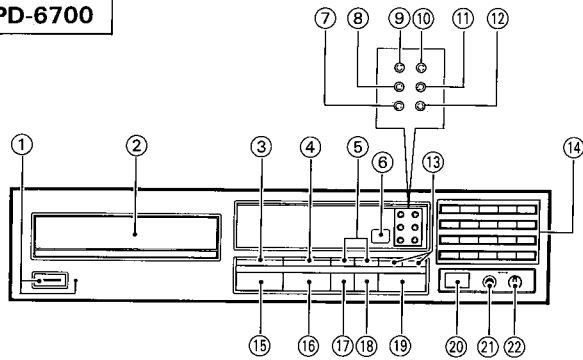

**PD-5700**

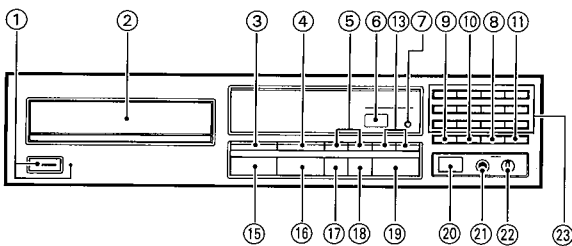

**PD-4700**

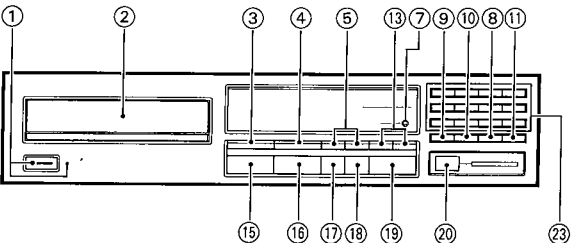

**PD-6700 only**

**PD-5700 only**

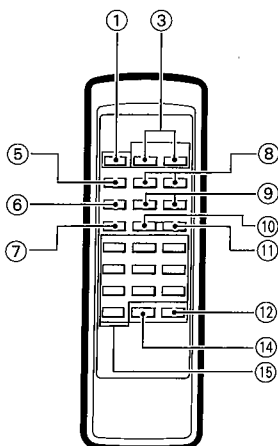
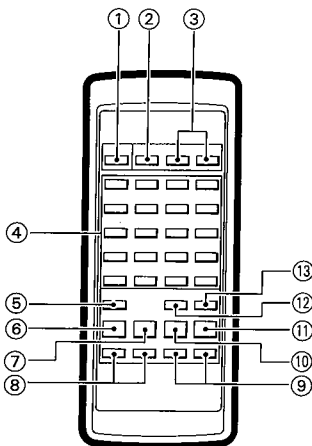

## FRONT PANEL

- ① POWER STANDBY/ON switch and indicator
- ② Disc tray
- ③ REPEAT button
- ④ HI-LITE SCAN button
- ⑤ MANUAL SEARCH (MANUAL) buttons (◀, ▶)
- ⑥ Remote sensor
- ⑦ TIME button
- ⑧ CHECK button
- ⑨ Program edit button (EDIT) (■ COMPU/ ■■ AUTO)
- ⑩ Program button (PGM)
- ⑪ CLEAR button
- ⑫ > 20 button
- ⑬ TRACK SEARCH (TRACK) buttons (◀◀, ▶▶)
- ⑭ TRACK NUMBER buttons (1–20)
- ⑮ OPEN/CLOSE button (▲)
- ⑯ RANDOM PLAY button
- ⑰ STOP button (■)
- ⑱ PAUSE button (■ ■)
- ⑲ PLAY button (▶)
- ⑳ PEAK SEARCH button
- ㉑ Headphones jack (PHONES)
- ㉒ Headphones volume control (PHONES LEVEL)
- ㉓ TRACK NUMBER buttons (1–10, +10, >20)

**NOTE:**

Items ㉑ and ㉒ are included on the U.K. and European models of the PD-4700.

## REMOTE CONTROL UNIT

Buttons listed here but not accompanied with explanations have the same functions as the corresponding front panel buttons.

- ① POWER button
- ② OPEN/CLOSE button
- ③ OUTPUT LEVEL buttons (–, +)
- ④ Track number buttons (1–20)
- ⑤ Hi-lite scan button (HI-LITE SCAN)
- ⑥ RANDOM PLAY button
- ⑦ STOP/clear button (■)
- ⑧ Manual search buttons (MANUAL ◀, ▶)
- ⑨ Track search buttons (TRACK ◀◀, ▶▶)
- ⑩ PAUSE button (■ ■)
- ⑪ PLAY button (▶)
- ⑫ Program button (PROGRAM/PGM)
- ⑬ > 20 button
- ⑭ > 10 button
- ⑮ Track number buttons (1–10)



# BASIC OPERATION

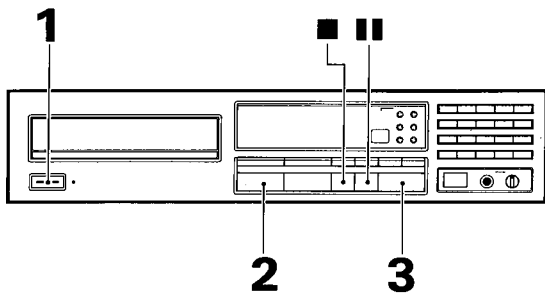

## To play a compact disc

1. Press the **POWER** switch to turn on power to the player.
2. Press the **OPEN/CLOSE** button.
  - Place a compact disc on the tray.
3. Press the **PLAY** button.

## To temporarily interrupt playback:

- During playback, press the **PAUSE** button (the **PAUSE** indicator [ ] will light).
- To recommence playback, press either the **PAUSE** button again, or the **PLAY** button.

## To stop playback:

- Press the **STOP** button.

## To remove a disc

- Reverse the procedures for disc loading.
1. Press the **OPEN/CLOSE** button.
  2. Remove the disc and return it to its protective case.
  3. Press the **OPEN/CLOSE** button to close the disc tray.
  4. Press the **POWER** switch to turn off the power.

## Demo mode:

- To enter the demo mode, press the **POWER** switch without disc, and press the [ ] button within 1 second. Various functions of this player appear on the display. To exit from demo mode, press any button.

## Regarding handling of compact discs:

- This player is designed to play back compact audio discs featuring the mark shown below.
- When holding discs, do not touch their signal surfaces. Hold the edges, or one edge and the center hole.
- Do not affix tape or seals to the disc's label surface, and take care to avoid scratching either of the disc's surfaces.
- Discs revolve at high speeds inside the player; do not attempt to play discs which are damaged (cracked or severely warped discs).

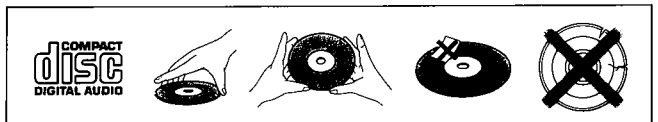

## NOTE:

- When setting an 8 cm CD single, do not use the 8 cm CD single adapter.
- Be sure to insert discs with the label surface facing up.
- Do not touch the disc's signal surface (the side reflecting a "rainbow" pattern, opposite the label side).
- Never attempt to load both 8 cm and 12 cm discs together, since disc damage or other malfunctions may result. Always load only one disc at a time.

**1**

**2**

**3**

**■ STOP:**

**■ PAUSE:**

Operations indicated by the [ ] mark are performed with the remote control unit.

**Continue**

## BASIC OPERATION

### TIMER START

- An audio timer can be used to start the playback from a specific desired time. When the audio timer turns the player's power on, the loaded disc will begin playing from track 1.

#### NOTE:

- If no disc has been loaded in the player, the player will enter the standby mode when the audio timer turns the player's power on.
- Pressing any function buttons before commencement of timer start cancels the timer start function.

#### Using the time button

To check the playing time:

Each time the TIME button is pressed, the display changes in the order (A) → (B) → (C) → (D) as noted below:

- (A) : Elapsed playing time.
- (B) : Remaining time of current track.
- (C) : Remaining time of all tracks remaining on disc.
- (D) : Total time of all tracks on disc.
- With track No.30 or more, the REMAIN time "(B)" cannot be displayed.
- During programmed playback, the "(C)" display will show the remaining time of all tracks programmed. The "(D)" display will show the total playing time of all tracks programmed.
- Each time a selection is programmed, the display will show the programmed number and the total playback time. When the total playback time exceeds 100 minutes or when any part of the 30th and subsequent selections on a disc is programmed, the display will not show the total playing time.
- During random playback, the "(C)" display will not be shown.

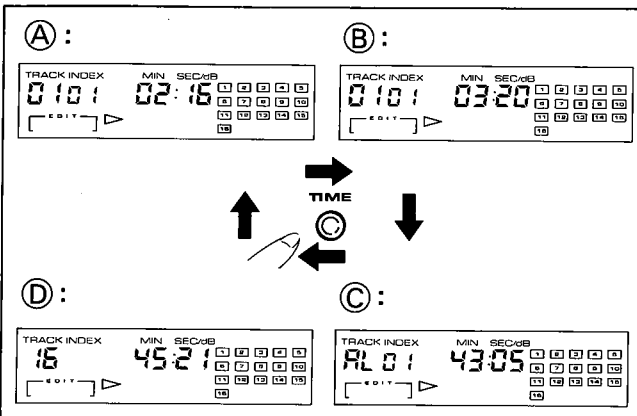

## VARIOUS OPERATIONS

### To begin playback from a particular track

#### Various Applications

Applies to PD-6700:

- Using the number buttons to select track numbers. Use corresponding buttons to select tracks 1–20. Use the [>20] button to select tracks 21 and above.

(A) Example: To designate track 26, press [>20] [2] [6].

#### NOTE:

Press each number button within five seconds of the last button.

Applies to PD-5700, PD-4700:

- Using the number buttons to select track numbers. Use corresponding buttons to select tracks 1–10. Use the [+10] button to select tracks 11 and above.

(A) Example: To select track 26, press [>20] [2] [6]. When using the PD-5700 remote control unit, use the [>10] button instead of the [>20] button.

(B) Example: To select track 26, press [+10] [+10] [6].

#### NOTE:

Press each number button within five seconds of the last button.

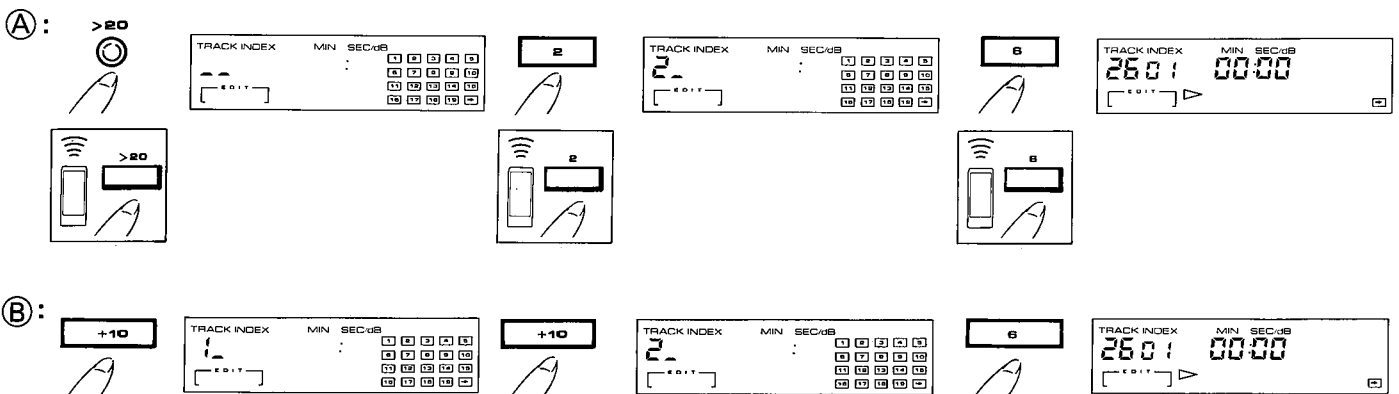

**During playback of one track, to advance immediately to the next track (track search)**

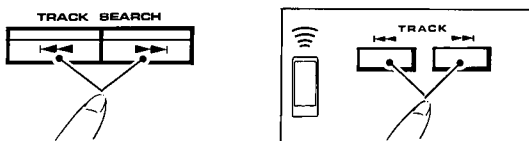

- When the [▶▶] button is pressed, playback will be advanced to the next track. By holding the button pressed, playback will continue to advance to further tracks in order.
- When the [◀◀] button is pressed, playback will return to the beginning of the currently playing track. By holding the button pressed, playback will be returned to the beginning of earlier tracks, in decreasing order.

**To start fast forward or fast reverse during playback (manual search)**

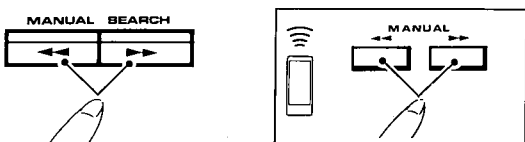

- The playback will be fast forwarded so long as the [▶▶] button is held pressed. Fast reverse will continue so long as the [◀◀] button is held pressed. If the disc is fast forwarded to the end of all tracks on the disc, the [End] indicator will be displayed, and the unit will enter the pause mode.

**To display the playing time of a particular track**

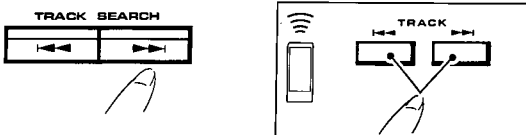

- Before beginning or after stopping playback, press the [▶▶] button to display the playing times of the tracks in order, beginning with track 1 (playing times of tracks 30 and above are not displayed).

**HI-LITE scan**

Using this feature will cause ten seconds of each track on the disc to be played back in order.

- To play ten seconds of each track at a point about one minute after the track beginning.



- To change the playback point, press the HI-LITE SCAN button at the desired point whilst in playback mode, and ten seconds of each subsequent track will be played back from the chosen point.
- When playback time of a track is less than one minute or is shorter than memorized time, Hi-Lite Scan playback is carried out from the beginning of the track for about 10 seconds.

**To repeat playback (repeat play)**



When pressed twice, all tracks will be repeated. (The [REP] indicator will light.)

- To cancel the repeat playback mode, press the REPEAT button again the [▶▶REP] or [REP] indicator will go out as appropriate.

**To choose random selection of the playback order (random play)**

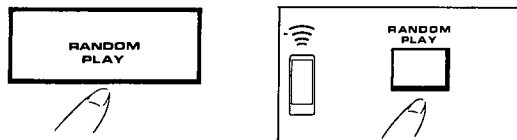

- Press the RANDOM PLAY button. When all tracks of the loaded disc have been played, playback will automatically stop. If specific tracks have been programmed, only those programmed tracks will be played (Program random play).

**To search for the peak volume level within a disc (peak search)**

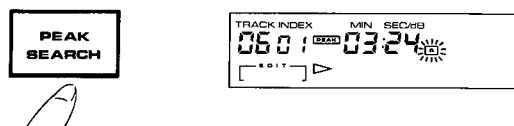

This function can be used to find the peak sound volume within a disc (when making recording on a cassette tape deck, knowing the source's peak level is necessary to set the recording level properly).

**1. With the player in the stop mode, press the PEAK SEARCH button.**

- The unit will enter the fast forward mode to search for the peak level on the disc. It will take about one minute to search an entire 60-minute CD. When less than the total number of tracks have been programmed, only those tracks will be searched for peak level.
- When the disc's peak level is found, the player will repeatedly play back the portion of the disc including that peak level (about 6 seconds of playback, including material before and after the peak level, will be heard). In the event that multiple peaks of similar level are located on the disc, the point found and played back may differ each time the peak search function is performed. When the peak level exists on the head of track, the player will enter into 3 seconds of playback.
- To cancel the PEAK SEARCH function, press the STOP button. During the peak search mode, the player will play back the sound volume level at -30dB.

**2. Press the PLAY button to begin playback, and begin recording on your cassette deck.**

**Adjusting the sound volume**

(PD-6700, PD-5700)

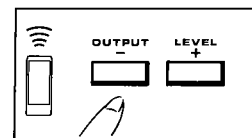

When the "-" side is pressed, the sound volume will be decreased by a small amount; when the "+" is pressed, sound volume will be increased by the same amount.

- The sound volume can be adjusted within the range 0dB to -25dB.
- If the tray is closed, adjusted volume level will be retained even if the power is turned off. However, if the power is turned off with an audio timer or unplugging the power cord, adjusted volume level will be erased.

## TO SELECT PLAYBACK OF TRACKS IN A SPECIFIC ORDER

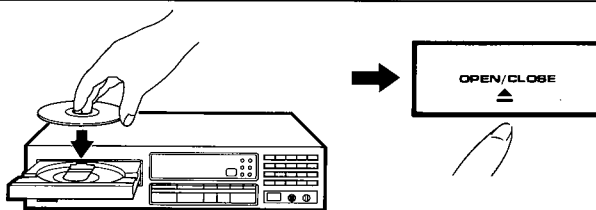
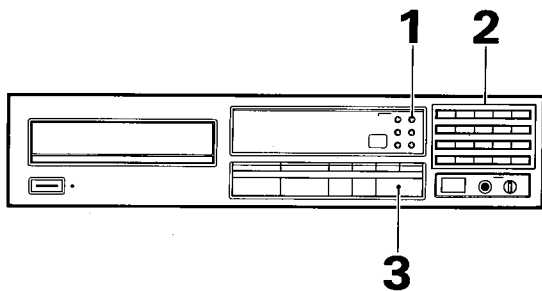

PD-6700

1

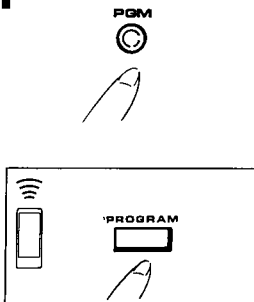

2

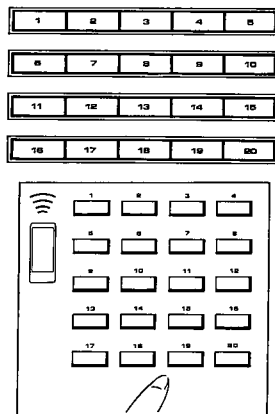

PD-5700/PD-4700

1

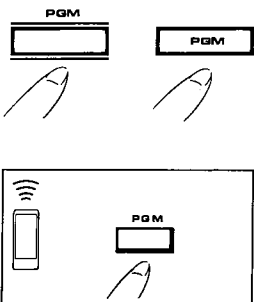

(PD-5700)

2

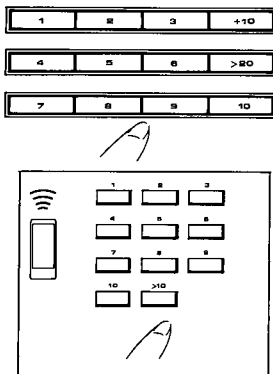

(PD-5700)

### Inputting the playback program

- With the player in the stop mode, press the **PROGRAM (PGM)** button.
- Use the number buttons to select the numbers of the desired tracks, in the order you want playback to proceed.
  - Up to 24 tracks (steps) can be programmed.
- When the **PLAY** button is pressed, the selected tracks will be played back in the order in which they were programmed.
  - If the tray is closed, the program contents will not be erased even if the power is turned off. However, if the power is turned off with an audio timer or unplugging the power cord, the program contents will be erased.

#### NOTE:

- Pressing the **PROGRAM (PGM)** button during normal playback and entering a program will automatically start the program after the currently-playing track ends. Also, if the **PLAY** button is pressed during playback, the program will start immediately.
- Each time a selection is programmed, the display will show the programmed number and the total playback time. When the total playback time exceeds 100 minutes or when any part of the 30th and subsequent selections on a disc is programmed, the display will not show the total playing time.

### About the direct program function

- Press the **PROGRAM (PGM)** button to enter the program mode.
- When the disc is played normally, the track search function can be used to move to succeeding tracks until a desired track is found. Alternately, the **HI-LITE** scan function can be used to move from track to track through the disc.
- If you wish to program the track currently playing, press the **PROGRAM (PGM)** button while the track is playing.

### About the pause program function

When programming tracks, the **PAUSE** button can be programmed if desired in place of a disc track. When a pause is programmed, "PA" will be displayed in place of a track number.

#### How to use the pause program function:

When recording both sides of a cassette tape, program the **PAUSE** button at the end of the last track to be recorded on side A of the tape; in this way, playback will be automatically interrupted, thus allowing you to turn the cassette tape over before resuming recording.

#### NOTE:

- A pause cannot be programmed as the first step (01) of a program, nor can it be programmed twice in succession.
- If a pause is programmed as the last step of a program, the player will not enter the pause mode.

TO SELECT PLAYBACK OF TRACKS IN A SPECIFIC ORDER

**To stop programmed playback**

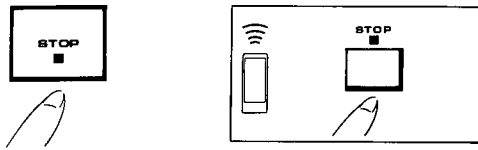

- When the STOP button is pressed, the programmed playback will stop (Program stop mode).

**To erase the program memory**

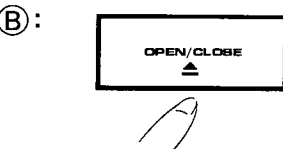
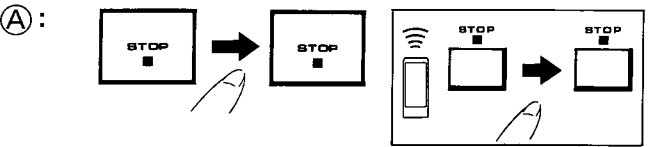

- Ⓐ : Press the STOP button to interrupt the programmed playback, then press the STOP button once again. The contents of the program memory will be erased.
- Ⓑ : The program memory will also be erased by pressing the OPEN/CLOSE button to open the disc tray when removing a disc.

**To erase a program**

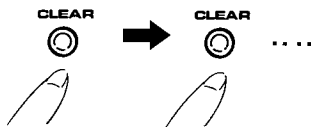

- The programmed tracks will be erased, beginning with the last programmed, in accordance with the number of times the CLEAR button is pressed.

**NOTE:**  
Contents of a program can be erased during playback as well. However, tracks preceding the currently playing track cannot be erased in this way.

**To confirm contents of the programmed memory**

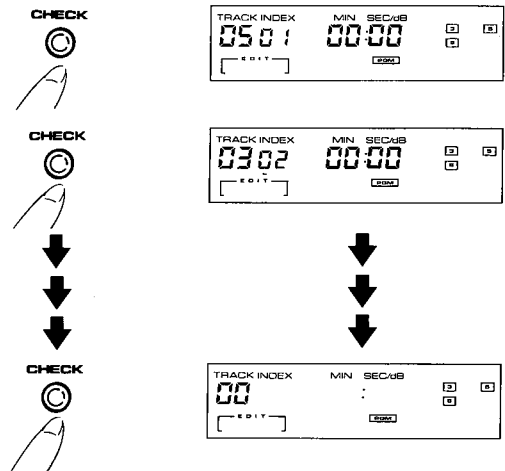

1. With the player in the program stop mode, press the CHECK button.
  - Each time the button is pressed, the programmed tracks will be displayed in the order they were programmed.
2. After confirming the last track programmed, the track number display will show "00".
3. When the CHECK button is pressed again, the display will return to that shown in step 1.

**To change the contents of programmed tracks already input**

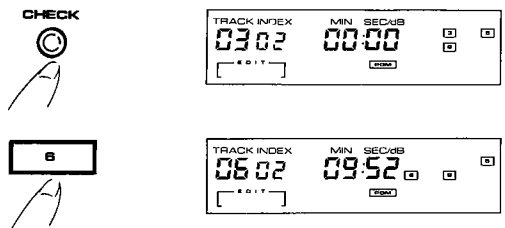

1. With the player in the program stop mode, press the CHECK button.
  - Continue pressing the CHECK button until the track number to be changed is displayed.
2. Use the number buttons to input the new track number desired.
  - Repeat steps 1 and 2 to change other tracks as desired.

# TO PLAYBACK A CD TO MATCH THE LENGTH OF A CASSETTE TAPE

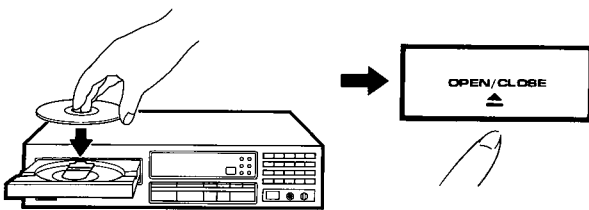
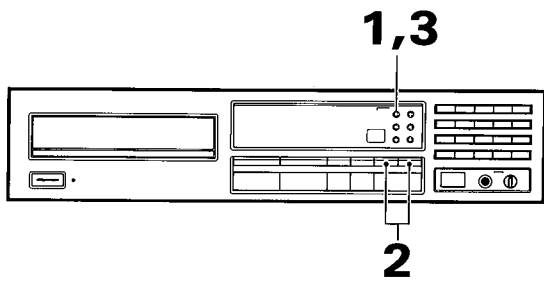

**1**

• COMPU PROGRAM EDIT mode



• AUTO PROGRAM EDIT mode

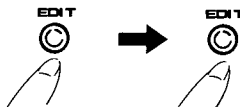

**2**



46 ↔ 54 ↔ 60  
90 ↔ 74

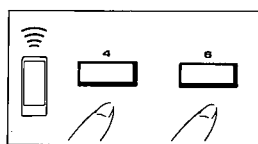
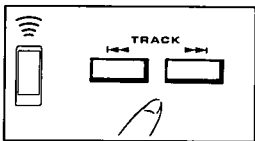

- This function is convenient when recording the contents of a CD onto a cassette tape.

## WHAT IS AUTO PROGRAM EDIT?

This function programs the playback of the number of CD tracks (beginning with the first and progressing in order) that can be contained within the time designated.

## WHAT IS COMPU PROGRAM EDIT?

This function automatically rearranges the order in which tracks are played back, so as to allow the closest possible matching of playback time to the time designated.

The unit will automatically select the tape length (46, 60 or 90 minutes) which will allow recording of all the tracks on the disc, then program the tracks.

### 1. Press the EDIT button once.

- In about three seconds, the unit will program the recording order to match the length of tape which will hold all the tracks.

**To perform compu program edit by designating the length of tape to be used**

### When the TRACK SEARCH buttons are used:

#### 1. Press the EDIT button.

- When the button is pressed once, the player will enter the Compu Program Edit mode.
- When the button is pressed twice, the player will enter the Auto Program Edit mode.

#### 2. Press the [◀◀] or the [▶▶] buttons to set the length (time) of the tape desired.

- Each time the buttons are pressed, the time setting will change in the following order:

→ 46 ↔ 54 ↔ 60 ↔ 74 ↔ 90 ←

Unit: Minutes

#### 3. Press the EDIT button once again.

### NOTE:

After using the TRACK SEARCH buttons to input the tape length, the number buttons cannot be used to input times. However, the [>20], or the [+10] button can be used to input times with the number buttons.

### When the number buttons are used:

#### 1. Press the EDIT button.

- When the button is pressed once, the player will enter the Compu Program Edit mode.
- When the button is pressed twice, the player will enter the Auto Program Edit mode.

#### 2. Press the number buttons to set the length (time) of the tape desired.

- In this way, the tracks which can be recorded on the tape's A and B sides will be automatically programmed.
- The display will first show the number of tracks and total playing time recordable on tape side A, then the number of tracks and playing time recordable on tape side B.

## TO PLAYBACK A CD TO MATCH THE LENGTH OF A CASSETTE TAPE

### (A) : COMPU PROGRAM EDIT (B) : AUTO PROGRAM EDIT

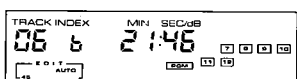
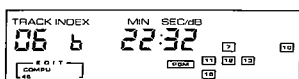

### To confirm the programmed results:

After completion of programming, press the EDIT button; each time the button is pressed, the program results will be alternately displayed for tape sides A and B.

- If the tray is not open, the program contents will not be erased even if the power is turned off.

However, if the power is turned off with an audio timer or unplugging the power cord, the program contents will be erased.

### NOTE:

- Up to 24 steps can be programmed.
- A disc which contains more than 24 selections sometimes cannot be programmed properly.

## TROUBLESHOOTING

Incorrect operations are often mistaken for trouble and malfunctions. If you think that there is something wrong with this component, check the points below. Sometimes the trouble may lie in another component. Investigate the other components and electrical appliances being used. If the trouble cannot be rectified even after exercising the checks listed below, ask your nearest PIONEER authorized service center or your dealer to carry out repair work.

| Symptom  | Cause  | Remedy  |
|--|--|---|
| Disc tray is not expelled when the OPEN/CLOSE button is pressed.           | <ul style="list-style-type: none"> <li>• Power plug is disconnected from outlet.</li> <li>• The POWER switch is OFF (STANDBY).</li> </ul>  | <ul style="list-style-type: none"> <li>• Connect plug to stereo amplifier or wall outlet.</li> <li>• Press the POWER switch ON.</li> </ul>  |
| When playback is started, it stops immediately. Pauses or stops playback   | <ul style="list-style-type: none"> <li>• Disc is loaded upside down.</li> <li>• Smudges etc., on the disc.</li> </ul>  | <ul style="list-style-type: none"> <li>• Load the disc correctly with the label side UP.</li> <li>• Clean the smudges from the disc and then play it again.</li> </ul>  |
| No sound.  | <ul style="list-style-type: none"> <li>• Output cords are connected incorrectly or loosely.</li> <li>• Incorrect operation of stereo amplifier.</li> <li>• Player is in the pause mode.</li> </ul>                                 | <ul style="list-style-type: none"> <li>• Connect properly.</li> <li>• Check the settings of stereo amplifier switches and sound volume controls.</li> <li>• Press the PLAY button .</li> </ul>  |
| Sound is distorted, noise is output.                                       | <ul style="list-style-type: none"> <li>• Incorrect connections.</li> <li>• Pin plugs or amplifier input terminals are dirty.</li> <li>• Interference is being picked up from a TV set.</li> </ul>                                  | <ul style="list-style-type: none"> <li>• Connect to amplifier's CD or AUX terminals etc. Do not connect to the PHONO input terminals.</li> <li>• Clean away dirt.</li> <li>• Switch OFF TV set, or move player away from TV set.</li> </ul>   |
| With certain discs, loud noise is produced, or play stops.                 | <ul style="list-style-type: none"> <li>• Disc is badly scratched or warped.</li> <li>• Disc is extremely dirty.</li> </ul>   | <ul style="list-style-type: none"> <li>• Replace the disc.</li> <li>• Clean the disc.</li> </ul>  |
| My TV set's picture is disrupted (or, my FM tuner picks up lots of noise). | <ul style="list-style-type: none"> <li>• Interference is being picked up from the CD player.</li> </ul>  | <ul style="list-style-type: none"> <li>• Either turn off the CD player or move the CD player farther away from the TV set (and FM tuner).</li> </ul>  |
| Cannot operate player with remote control unit. (PD-6700, PD-5700 only)    | <ul style="list-style-type: none"> <li>• Batteries have expired.</li> <li>• Remote control unit is too far away from player, or angle is wrong.</li> <li>• There is an obstacle between remote control unit and player.</li> </ul> | <ul style="list-style-type: none"> <li>• Replace batteries.</li> <li>• The operating range of the remote control unit, is up to about 7 m from, and within angles of 30 degrees left and right of the sensor window on the player.</li> <li>• Operate the remote control unit from a different position, or remove the obstacle.</li> </ul> |

# SPECIFICATIONS

## 1. General

Type ..... Compact disc digital audio system  
Usable discs ..... Compact Disc  
Power requirements  
U.K. and Australian models ..... AC 230—240V, 50/60Hz  
European model ..... AC 220—230V, 50/60Hz  
U.S. and Canadian models ..... AC 120V, 60Hz  
Multi-voltage model ..... AC 110/120—127/220/240V  
(switchable) 50/60Hz  
Power consumption ..... 12W  
Operating temperature ..... +5°C—+35°C  
(+41°F—+95°F)  
Weight ..... 3.6kg (7lb, 15oz)  
External dimensions  
PD-4700: U.K. and European models,  
PD-5700: U.S., Canadian, U.K. and European models,  
PD-6700: All models ..... 420(W) × 276(D) × 101(H)mm  
16-9/16(W) × 10-7/8(D) × 4(H) in.  
Other models ..... 420(W) × 276(D) × 96(H)mm  
16-9/16(W) × 10-7/8(D) × 3-13/16(H) in.

## 2. Audio section

Frequency response ..... 2Hz—20kHz  
Dynamic range ..... 96dB or more (EIAJ)  
Total harmonic distortion ..... 0.003% or less (EIAJ)  
Output voltage ..... 2.0V  
Wow and flutter ..... Limit of measurement  
(±0.001% W.PEAK) or less (EIAJ)  
Number of channels ..... 2 channels (stereo)

## 3. Output terminal

- Audio line output terminals
- CD-DECK SYNCHRO terminal
- Control input/output terminals  
(PD-4700: All models,  
PD-5700: U.S. and Canadian models only,  
PD-6700: U.S. and Canadian models only)
- Headphone jack (with volume control)  
(PD-4700: U.K. and European models only,  
PD-5700: All models,  
PD-6700: All models)
- Optical digital output terminal  
(PD-6700: All models)

## 4. Functions

- Play
- Pause
- Stop
- Manual search
- Track search
- Peak search
- Hi-lite scan
- Direct selection
- Single track repeat
- All track repeat
- Programmed repeat
- Random play repeat
- Programmed random play repeat
- Programmed playback (up to 24 tracks)
- Pause program
- Program check
- Program correction
- Program clear
- Auto program edit
- Compu program edit
- Digital level control (PD-6700/PD-5700: Remote control only)
- Random play
- Programmed random play
- Program hold
- Level hold
- Timer start
- CD-deck synchro

## 5. Accessories

- Remote control unit (PD-6700, PD-5700) ..... 1
- Size AAA/R03 dry cell batteries (PD-6700, PD-5700) ..... 2
- Output cable ..... 1
- Control cord  
(PD-6700: U.S. and Canadian models)  
(PD-5700: U.S. and Canadian models)  
(PD-4700: All models) ..... 1
- Operating instructions ..... 1

### NOTE:

*The specifications and design of this product are subject to change without notice, due to improvements.*

Published by Pioneer Electronic Corporation.  
Copyright © 1991 Pioneer Electronic Corporation.  
All rights reserved.

**PIONEER ELECTRONIC CORPORATION** 4-1, Meguro 1-Chome, Meguro-ku, Tokyo 153, Japan

**PIONEER ELECTRONICS [USA] INC.** 2265 East 220th Street, Long Beach, California 90810, U.S.A.

P.O. BOX 1720, Long Beach, California 90801, U.S.A.

**PIONEER ELECTRONICS OF CANADA, INC.** 505 Cochrane Drive, Markham, Ontario L3R 8E3, Canada

**PIONEER ELECTRONIC [EUROPE] N.V.** Keetberglaan 1, 2740 Beveren, Belgium, TEL: 03/750.05.11

**PIONEER ELECTRONICS AUSTRALIA PTY. LTD.** 178-184 Boundary Road, Braeside, Victoria 3195, Australia, TEL: [03] 580-9911